

# PGFR

The PGFR series of flange type right angle helical gearbox provide a wide range of performance levels to high positioning accuracy and motion control applications, particularly when high precision and high torsional rigidity are required. Frame sizes 42-142 mm with the best level of backlash  $\leq 2$  arc-min. Nominal input speed up to 10000 rpm. The PGFR is specially well suited to work with pinion and rack for linear operation. Commonly adapted in metal cutting machines, wood processing equipment, machine centers and highly dynamic motion control systems. In-line configuration (PGF series) is also available with max. Frame size 142 mm.



Frame Size (mm)	42, 60, 90, 115, 142
Ratio	3 : 1 - 200 : 1
Nominal Input Speed (rpm)	3,000 - 5,000
Max Input Speed (rpm)	5,000 - 10,000
Backlash (arc-min)	1 Stage : 2 - 8 2 Stages : 4 - 10
Noise Level (dBA / 1m)	62 - 70

## Features

- ▶ 3 levels of backlash, 5 frame sizes available from 42-142 mm.
- ▶ Premium and precision gear design, ratios from 3-200:1.
- ▶ One-piece planet carrier/output shaft, high rigidity and radial load capacity.
- ▶ Hardened and ground gearing, high wear resistance and impact toughness.
- ▶ One-piece ring gear/housing, high precision and torque output.
- ▶ Planets with full needle bearing support.
- ▶ IP65 enclosure and synthetic lubricant, maintenance-free service life.

# PGFR Single Stage Dimensions

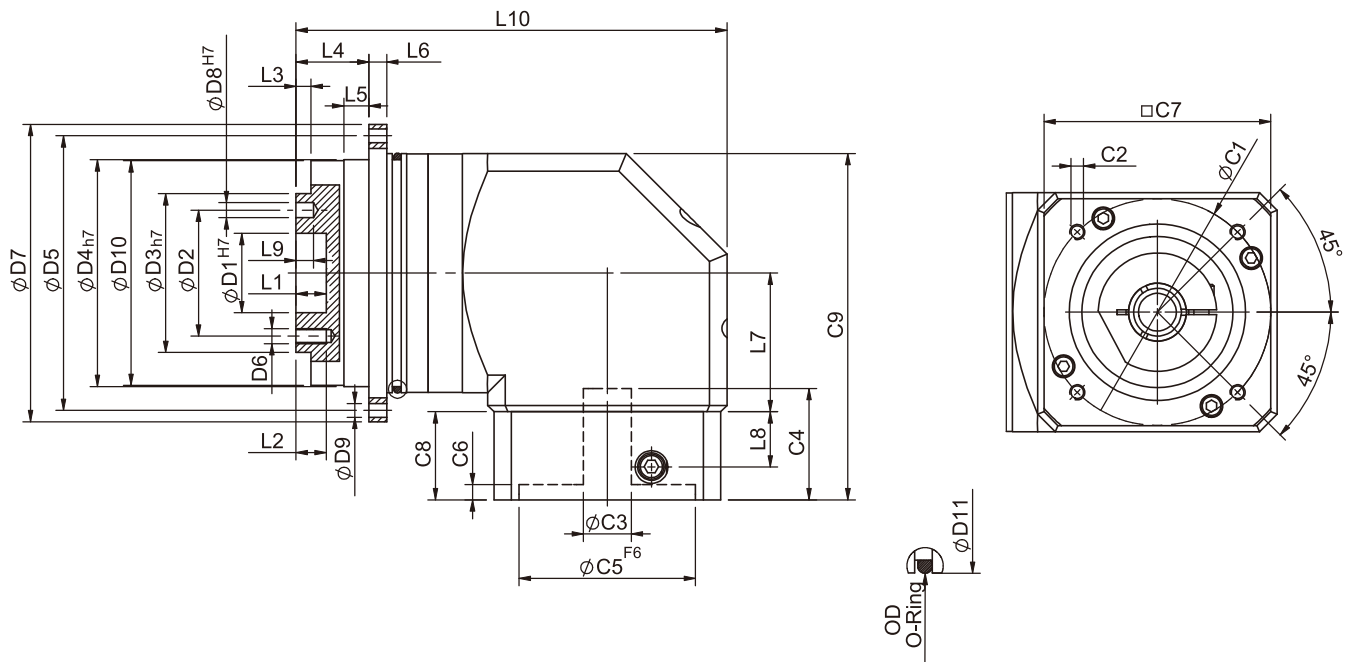

## Specifications

Unit:mm

Dimensions	PGFR42	PGFR60	PGFR90	PGFR115	PGFR142
D1 <sub>H7</sub>	12	20	31.5	40	50
D2	20	31.5	50	63	80
D3 <sub>h7</sub>	28	40	63	80	110
D4 <sub>h7</sub>	47	64	90	110	140
D5	67	79	109	135	168
D6	M3x0.5P	M5x0.8P	M6x1.0P	M6x1.0P	M8x1.25P
D7	72	86	118	145	179
D8 <sub>H7</sub>	3	5	6	6	8
D9	3.4	4.5	5.5	5.5	6.6
D10	46.2	63.2	89.2	109.2	139.2
D11	60	70	95	120	152
L1	4	8	12	12	12
L2	6	7.2	12	13.5	16
L3	3	3	6	6	6
L4	19.5	19.5	29	29	38
L5	7	7	10	10	14.6
L6	4	4	7	8	10
L7	32.2	44.8	55	69	71
L8	13.5	21.5	22	32	44.7
L9	4	6	7	7	7
L10	92.2	123.9	171.1	200.2	250.7
C1 <sup>2</sup>	46	70	90	90	145
C2 <sup>2</sup>	M4x0.7P	M5x0.8P	M6x1.0P	M6x1.0P	M8x1.25P
C3 <sup>2</sup>	≤8/≤11	≤14/≤19	≤19/≤24	≤24/≤32	≤35
C4 <sup>2</sup>	29	34	44	53.5	76.8
C5 <sup>2</sup> <sub>F6</sub>	30	50	70	70	110
C6 <sup>2</sup>	6	5	5	5.5	9
C7 <sup>2</sup>	42.6	60	90	115	140
C8 <sup>2</sup>	25	33	35	48	65
C9 <sup>2</sup>	75.3	112.8	137.5	176.5	225.5
OD	56x2	66x2	90x3	110x3	145x3

★ C1~C9 are motor specific dimensions (metric std shown). Size may vary according to motor flange.

★ Specification subject to change without notice.

# PGFR Double Stage Dimensions-1

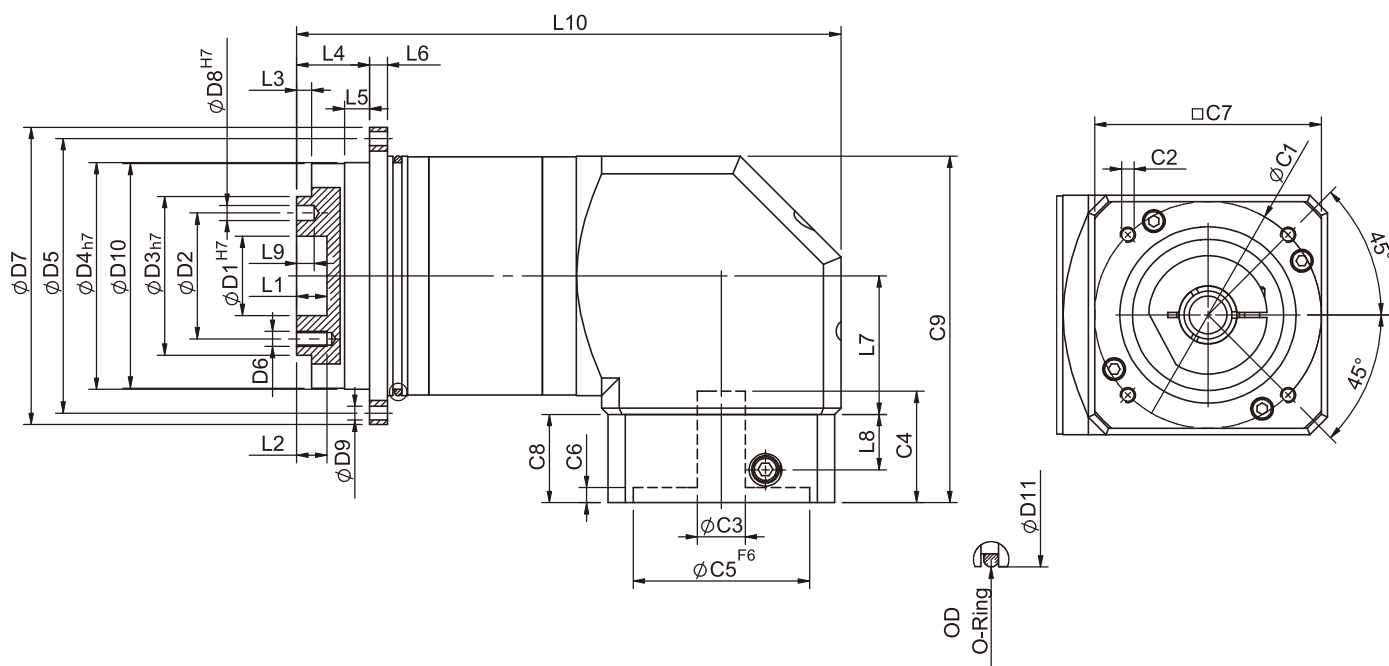

## Specifications

Unit:mm

Dimensions	PGFR42	PGFR60	PGFR90
D1 <sub>H7</sub>	12	20	31.5
D2	20	31.5	50
D3 <sub>H7</sub>	28	40	63
D4 <sub>H7</sub>	47	64	90
D5	67	79	109
D6	M3x0.5P	M5x0.8P	M6x1.0P
D7	72	86	118
D8 <sub>H7</sub>	3	5	6
D9	3.4	4.5	5.5
D10	46.2	63.2	89.2
D11	60	70	95
L1	4	8	12
L2	6	7.2	12
L3	3	3	6
L4	19.5	19.5	29
L5	7	7	10
L6	4	4	7
L7	32.2	44.8	55
L8	13.5	21.5	22
L9	4	6	7
L10	119.9	159.3	216.1
C1 <sup>2</sup>	46	70	90
C2 <sup>2</sup>	M4x0.7P	M5x0.8P	M6x1.0P
C3 <sup>2</sup>	≤8/≤11	≤14/≤19	≤19/≤24
C4 <sup>2</sup>	29	34	44
C5 <sup>2</sup> <sub>F6</sub>	30	50	70
C6 <sup>2</sup>	6	5	5
C7 <sup>2</sup>	42.6	60	90
C8 <sup>2</sup>	25	33	35
C9 <sup>2</sup>	78.5	112.8	137.5
OD	56x2	66x2	90x3

★ C1~C9 are motor specific dimensions (metric std shown). Size may vary according to motor flange.

★ Specification subject to change without notice.

# PGFR Double Stage Dimensions-2

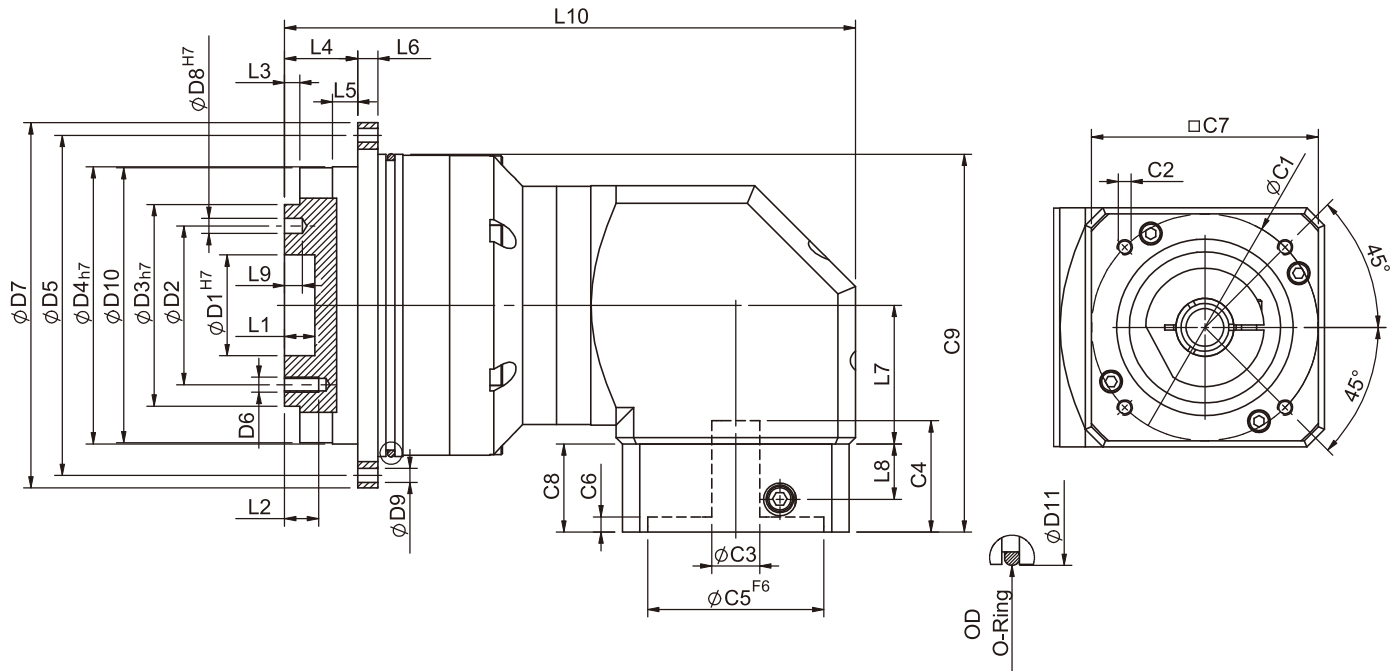

## Specifications

Unit:mm

Dimensions	PGFR60T	PGFR90T	PGFR115T	PGFR142T
D1 <sub>H7</sub>	20	31.5	40	50
D2	31.5	50	63	80
D3 <sub>h7</sub>	40	63	80	100
D4 <sub>h7</sub>	64	90	110	140
D5	79	109	135	168
D6	M5x0.8P	M6x1.0P	M6x1.0P	M8x1.25P
D7	86	118	145	179
D8 <sub>H7</sub>	5	6	6	8
D9	4.5	5.5	5.5	6.6
D10	63.2	89.2	109.2	139.2
D11	70	95	120	152
L1	8	12	12	12
L2	7.2	12	13.5	16
L3	3	6	6	6
L4	19.5	29	29	38
L5	7	10	10	14.6
L6	4	7	8	10
L7	32.2	44.8	55	69
L8	13.5	21.5	22	32
L9	6	7	7	7
L10	126.6	171.3	226.6	270.7
C1 <sup>2</sup>	46	70	90	90
C2 <sup>2</sup>	M4x0.7P	M5x0.8P	M6x1.0P	M6x1.0P
C3 <sup>2</sup>	≤8/≤11	≤14/≤19	≤19/≤24	≤24/≤32
C4 <sup>2</sup>	29	34	44	53.5
C5 <sup>2</sup> <sub>F6</sub>	30	50	70	70
C6 <sup>2</sup>	6	5	5	5.5
C7 <sup>2</sup>	42.6	60	90	115
C8 <sup>2</sup>	25	33	35	48
C9 <sup>2</sup>	84.4	125.3	150	176.5
OD	66x2	90x2	110x3	145x3

\* C1~C9 are motor specific dimensions (metric std shown). Size may vary according to motor flange.

\* Specification subject to change without notice.

# PGFR Flange Dimensions

PACR  
PBE  
PBC  
PGSH  
PGS  
PAN  
PANR  
PNS  
PNSR  
PUL  
PUA  
PUR  
PHF  
PGF  
PHFR  
PGFR

PGFR42

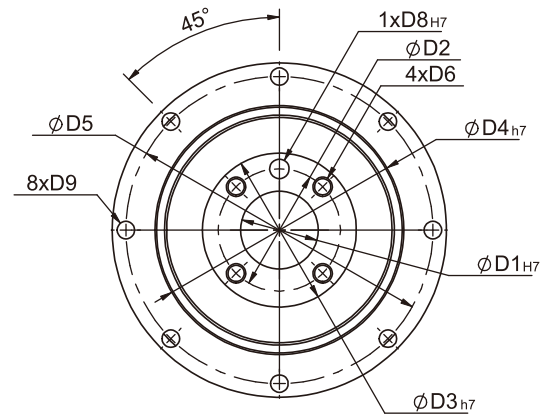

PGFR60  
PGFR90

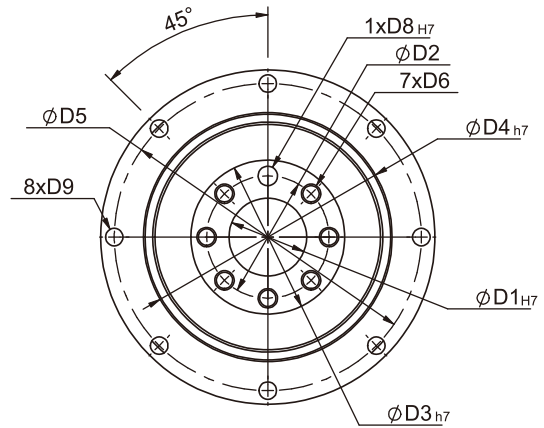

PGFR115

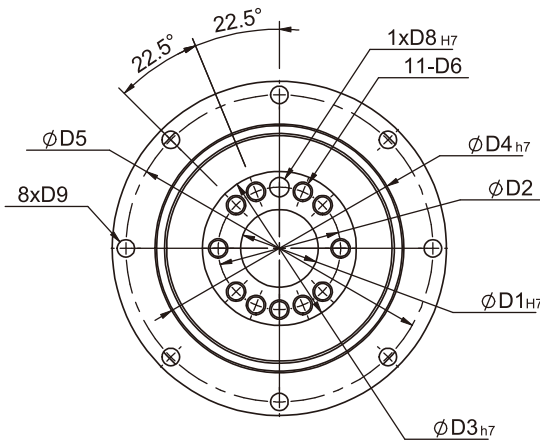

PGFR142

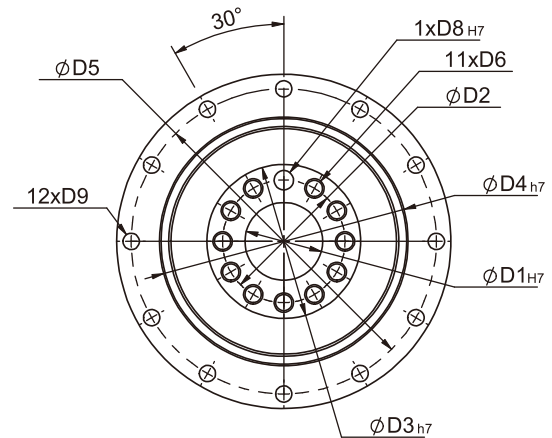

## Specifications

Unit:mm

Dimensions	PGFR42	PGFR60	PGFR90	PGFR115	PGFR142
D1H7	12	20	31.5	40	50
D2	20	31.5	50	63	80
D3h7	28	40	63	80	100
D4h7	47	64	90	110	140
D5	67	79	109	135	168
D6	M3x0.5P	M5x0.8P	M6x1.0P	M6x1.0P	M8x1.25P
D8H7	3	5	6	6	8
D9	3.4	4.5	5.5	5.5	6.6

\* Specification subject to change without notice.

# PGFR Specifications

Specifications		Stage	Ratio	PGFR-42	PGFR-60	PGFR-90	PGFR-115	PGFR-142
Nominal Output Torque $T_{2N}$	N · m	1	3	-	40	105	180	340
			4	16	43	110	240	500
			5	17	50	130	290	600
			7	14	44	125	270	530
			10	17	50	130	260	540
			14	14	44	125	270	530
		20	11	37	95	220	430	
		Stage	Ratio	PGFR-42	PGFR-60/ PGFR-60T	PGFR-90/ PGFR-90T	PGFR-115T	PGFR-142T
		2	15	-	40	105	180	600
			20	16	43	110	240	600
			25	17	50	130	290	600
			30	17	40	105	180	600
			35	17	50	130	290	600
			40	16	43	110	240	600
			50	17	50	130	290	600
			70	14	44	125	270	530
			100	11	37	95	220	430
			140	14	44	125	270	530
		200	11	37	95	220	430	
Emergency Stop Torque $T_{2NOT}$	N · m		(3.0 times of Nominal Output Torque) (*Max. Output Torque $T_{2B}$ =60% of Emergency Stop Torque)					
Nominal Input Speed $n_{1N}$	rpm	1,2	3-200	5000	5000	4000	4000	3000
Max. Input Speed $n_{1max}$	rpm	1,2	3-200	10000	10000	8000	8000	5000
Micro Backlash P0	arcmin	1	3-20	-	-	≤4	≤2	≤2
		2	15-200	-	-	≤6	≤4	≤4
Precision Backlash P1	arcmin	1	3-20	≤6	≤6	≤6	≤4	≤4
		2	15-200	≤8	≤8	≤8	≤7	≤7
Standard Backlash P2	arcmin	1	3-20	≤8	≤8	≤8	≤6	≤6
		2	15-200	≤10	≤10	≤10	≤9	≤9
Torsional Rigidity	N · m /arcmin	1,2	3-200	6	12	28	75	145
Max. Bending Moment $M_{2kB}^1$	N	1,2	3-200	22.5	36	76	140	950
Max. Axial Load $F_{2aB}^1$	N	1,2	3-200	465	635	1060	1580	6400
Operating Temp.	°C		3-200	-10°C ~ +90°C				
Service Life	hr		3-200	20,000 (10,000 Continuous Operation)				
Efficiency	%	1	3-20	≥95%				
		2	15-200	≥92%				
Weight	kg	1	3-20	1.1	2.2	6.3	13.5	25.1
		2	15-200	1.6	2.9/2.1	8.3/5.0	14.8	26.7
Mounting Position	-	1,2	3-200	Any Direction				
Noise Level <sup>2</sup>	dBA/1m	1,2	3-200	62	64	66	68	70
Protection Class	-	1,2	3-200	IP65				
Lubrication	-	1,2	3-200	Synthetic Lubricant				
Inertia(J1)								
Stage	Ratio	unit	PGFR-42	PGFR-60	PGFR-90	PGFR-115	PGFR-142	
1	3/4/5/7	Kg · cm <sup>2</sup>	0.06	0.40	2.28	6.87	24.2	
	10/14/20		0.05	0.30	1.45	4.76	14.5	
2	15/20/25/35		0.06	0.40(0.08)	2.28(0.72)	3.02	7.83	
	Others		0.05	0.30(0.06)	1.45(0.38)	1.64	5.00	

\* 1. Applied to the output shaft center at 100 rpm.

\* 2. Environment noise level 30 dB; distance 1m; measured under free loading with input speed 3000 rpm; ratio = 10 (1-stage) or ratio = 100 (2-stage).

※The above figures/specifications are subject to change without prior notice.

Products due to human error, natural disasters or other factors lead to poor or damaged, will not be covered under warranty.